

R400

SERIES

Forged Steel
Medium-Heavy Duty

Load Capacity: 300 to 1,800 lbs.

Quality Features

- **HOT FORGED SWIVEL RACEWAY.**
SAE-1050 hot forged steel assembly with acutely formed and matched raceways that contain a full complement of 3/8" diameter polished alloy steel ball bearings. Secondary raceway uses tapered roller bearing for added endurance.
- **ADJUSTABLE KING PIN.**
Special 3/4" diameter integral forged king pin bolt and nut is fully adjustable whenever necessary.
- **LUBRICATION FITTINGS.**
Easily accessible pressure fitting is added to main and secondary ball race, and to wheel bearings through either a fitting in the head of axle.
- **REINFORCED WELDED FORK LEGS.**
Side forks are extra-wide, offset, and continuously welded for added strength.

This series is the strongest caster available with standard 2" wheel width. Hot forged top plate, bottom retainer, and yoke base are all made with SAE-1050 quality grade steel to provide superior strength when compared to stamped metal casters. King pin is a special 5/8" diameter hardened alloy steel bolt and nut that is fully adjustable.

Typical uses include:

- Heavy Skywall Carts
- Glass Transfer Trucks
- Lumber Carts and Dollies
- Jigs and Fixtures
- Light-Duty Trailers

The perfect replacement caster for lighter duty stamped casters that don't hold up under severe applications. Standard finish is industrial blue enamel.

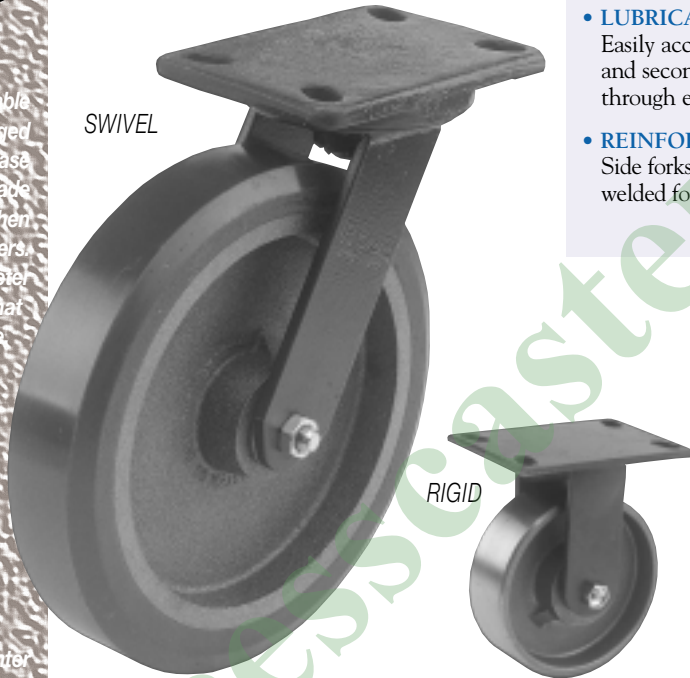

Options

- Wheel Thread Guard
- Grease Seals for Swivel Raceways
- High-Temperature Wheels
- Conductive or Static-Dissipative Wheels

SWIVEL BEARING RACEWAY R400 SERIES

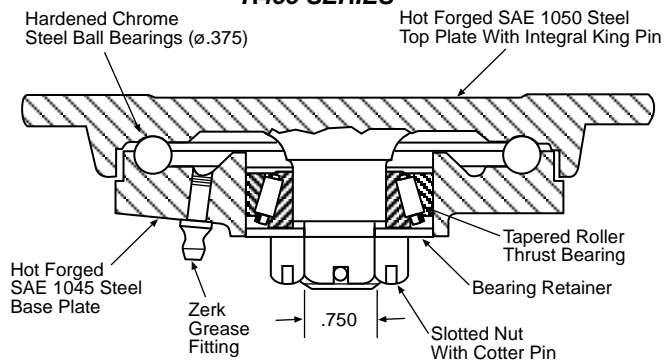

Wheel Selection

CAST IRON HUB	CAST IRON HUB	CAST IRON HUB	CAST IRON HUB	PHENOLIC	CAST IRON
ADVANCED ELASTOMER	MOLD-ON RUBBER	MOLD-ON POLYURETHANE	MOLD-ON SOFT POLY		
PAGE 106	PAGE 120	PAGE 128	PAGE 130	PAGE 134	PAGE 138

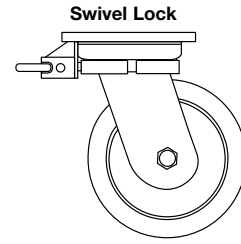
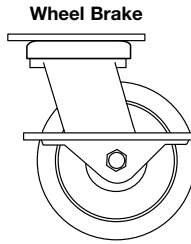
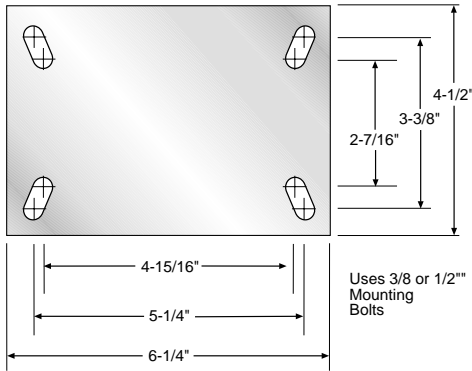

Wheel Brake

This wheel brake is an inexpensive, yet effective way to render all types of equipment safe while being stored, loaded or unloaded. Operation is simple and straightforward. Pressing down firmly on either end of the brake pedal actuates a camming mechanism which locks the wheel against rotation. Returning the pedal to "neutral" (horizontal to floor-line) unlocks the brake and enables the caster to "free-wheel" once again.

Swivel Lock

This plunger-type swivel lock, with cast malleable iron body can be welded to any of the light-duty casters.

Diameter	Tread Width	Load Capacity	Wheel Material	Bearing	Swivel Part Number	Rigid Part Number	Approx. Weight	Overall Height	Swivel Radius
3 1/4	2	700	CAST IRON	ROLLER	SC-432-CI	RC-432-CI	6-4/5	5-1/4	3-3/16
			PHENOLIC	ROLLER	SC-432-PR	RC-432-PR	5-3/10		
4	2	300	MOLD-ON RUBBER	ROLLER	SC-442-RS	RC-442-RS	6-9/10	5-5/8	3-9/16
		580	ADVANCED ELASTOMER	PRECISION BALL	SC-442-PXAE	RC-442-PXAE	7-1/10		
			POLYURETHANE / CAST IRON HUB	ROLLER	SC-442-TAE	RC-442-TAE			
			SOFT POLY / CAST IRON HUB	ROLLER	SC-442-PS	RC-442-PS			
		800	PHENOLIC	ROLLER	SC-442-PR	RC-442-PR	5-1/2		
1100	CAST IRON	ROLLER	SC-442-CI	RC-442-CI	8-7/10				
5	2	350	MOLD-ON RUBBER	ROLLER	SC-452-RS	RC-452-RS	8-3/5	6-1/2	4-1/4
		700	ADVANCED ELASTOMER	PRECISION BALL	SC-452-PXAE	RC-452-PXAE	8-1/2		
			POLYURETHANE / CAST IRON HUB	ROLLER	SC-452-TAE	RC-452-TAE			
			SOFT POLY / CAST IRON HUB	ROLLER	SC-452-PS	RC-452-PS			
		1000	PHENOLIC	ROLLER	SC-452-PR	RC-452-PR	6-9/10		
1300	CAST IRON	ROLLER	SC-452-CI	RC-452-CI	10-1/10				
6	2	410	MOLD-ON RUBBER	ROLLER	SC-462-RS	RC-462-RS	11-2/5	7-1/2	5
			PHENOLIC	ROLLER	SC-463-RS	RC-463-RS	12-3/10	8-1/2	5-1/8
		1200	PHENOLIC	ROLLER	SC-462-PR	RC-462-PR	8-1/2	7-1/2	5
			PHENOLIC	ROLLER	SC-463-PR	RC-463-PR	9-2/5	8-1/2	5-1/8
			ADVANCED ELASTOMER	PRECISION BALL	SC-462-PXAE	RC-462-PXAE	11-2/5	7-1/2	5
			ADVANCED ELASTOMER	PRECISION BALL	SC-463-PXAE	RC-463-PXAE	12-3/10	8-1/2	5-1/8
			ADVANCED ELASTOMER	ROLLER	SC-462-TAE	RC-462-TAE	11-2/5	7-1/2	5
			ADVANCED ELASTOMER	ROLLER	SC-463-TAE	RC-463-TAE	12-3/10	8-1/2	5-1/8
			POLYURETHANE / CAST IRON HUB	ROLLER	SC-462-PS	RC-462-PS	11-2/5	7-1/2	5
			POLYURETHANE / CAST IRON HUB	ROLLER	SC-463-PS	RC-463-PS	12-3/10	8-1/2	5-1/8
SOFT POLY / CAST IRON HUB	ROLLER	SC-462-PS8	RC-462-PS8	11-2/5	7-1/2	5			
SOFT POLY / CAST IRON HUB	ROLLER	SC-463-PS8	RC-463-PS8	12-3/10	8-1/2	5-1/8			
1600	CAST IRON	ROLLER	SC-462-CI	RC-462-CI	12-3/5	7-1/2	5		
	CAST IRON	ROLLER	SC-463-CI	RC-463-CI	13-1/2	8-1/2	5-1/8		
8	2	500	MOLD-ON RUBBER	ROLLER	SC-482-RS	RC-482-RS	14	9-1/2	6-1/8
		1400	PHENOLIC	ROLLER	SC-482-PR	RC-482-PR	10-3/5		
			ADVANCED ELASTOMER	PRECISION BALL	SC-482-PXAE	RC-482-PXAE	14		
		POLYURETHANE / CAST IRON HUB	ROLLER	SC-482-TAE	RC-482-TAE				
		SOFT POLY / CAST IRON HUB	ROLLER	SC-482-PS	RC-482-PS				
1800	CAST IRON	ROLLER	SC-482-CI	RC-482-CI	16-3/10				
10	2	650	MOLD-ON RUBBER	ROLLER	SC-4102-RS	RC-4102-RS	19	11-1/2	7-3/4
		1700	POLYURETHANE / CAST IRON HUB	ROLLER	SC-4102-PS	RC-4102-PS			
			SOFT POLY / CAST IRON HUB	ROLLER	SC-4102-PS8	RC-4102-PS8			