

CARPETMASTER

Load Capacity: 110 to 165 lbs.

SERIES

Possibly the BEST Caster for office chairs or hospital I.V. poles! Our "slant" donut-style wheel is compounded with a highly resilient, extra-soft neoprene rubber which enables this caster to swivel and roll even on heavy pile carpet. Eliminates the need for floor mats under office chairs.

For use on the following:

- Executive High-Back Office Chairs
- Conference Room Chairs
- Ergonomic Work Stations
- Static Sensitive Environments
- High-and-Diettes
- Hospital I.V. Poles

Ball bearing wheels and standard thread guards* eliminates snag and prevents dragging. A much better alternative to cheap plastic twin-wheel casters.

*Thread guards apply to 3-inch models only.



SWIVEL

Quality Features

- **FOUR-SIDED, DOUBLE BALL RACEWAY.**
Hardened steel ball bearings touch upper and lower swivel raceway "on all four sides." This protects the pin from shock loading for free swiveling under heavy loads.
- **HEAT-TREATED MOVING PARTS.**
All moving parts are hardened to a precise molecular depth and Rockwell hardness. This extends caster life under rugged conditions and shock loads.
- **THREAD GUARDS.**
Thread guards keep unwanted materials out of the wheel bearings thus increasing the life of the caster. Thread guards are standard on nearly all Darnell wheels (except 2" diameter).
- **SILENT, DONUT-STYLE WHEELS.**
Highly resilient Neoprene wheel is extra-soft and is standard with ball bearings for a smooth and quiet ride.
- **LUSTROUS DECORATIVE FINISHES.**
Highly polished chrome finish adds beauty to functionality. Brass and other decorative finishes also available.

Options

- Hollow King Pin for bolt mounting
- Powder Coating
- Gray, Non-Marking Wheels
- Conductive or Static Dissipative Wheels

FOUR SIDED DOUBLE BALL BEARING RACEWAY 50 SERIES

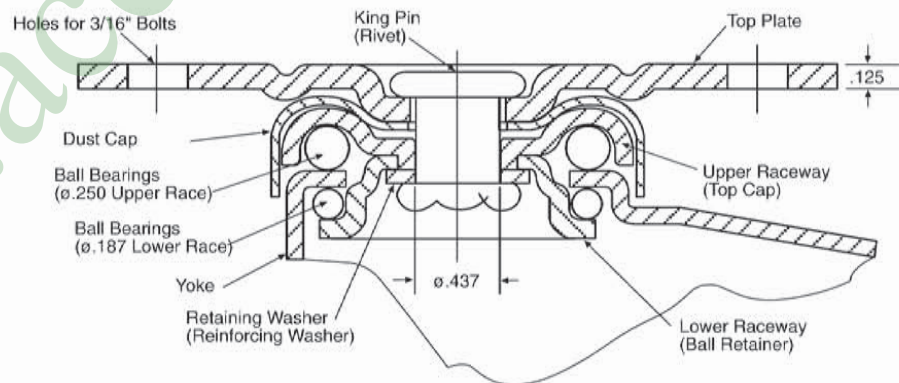

Wheel Selection

NEOPRENE RUBBER

PAGE 84



HI-CAP NEOPRENE

PAGE 86



EXTRA-SOFT NEOPRENE

PAGE 90



HARD RUBBER

PAGE 88



TOP PLATE

STANDARD

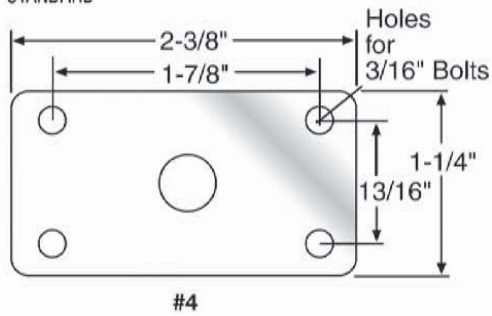

ALTERNATE

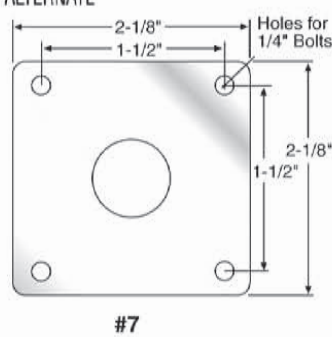

**CARPETMASTER
CARPETMASTER 2
Office Chair**



STEMS

"O" STEM TABLE



Dimension D	Dimension L	Stem Number
3/8"	1"	O13-38-1
*3/8"	1-1/4"	O13-38-114
7/16"	1"	O13-716-1
7/16"	1-1/4"	O13-716-114
7/16"	1-1/2"	O13-716-112

Other stem sizes and dimensions available.
*Special Order/Minimum Quantity



"L" STEM TABLE



Dimension T	Dimension L	Stem Number
3/8"-16	1"	L13-3816-1
*3/8"-16	1-1/4"	L13-3816-114
7/16"-14	1"	L13-71614-1
*7/16"-14	1-1/4"	L13-71614-114

Other stem sizes and dimensions available.
*Special Order/Minimum Quantity

"S" stem

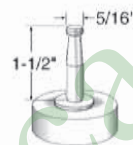

For effective load height, subtract .125" from overall height for stem casters.

Brake available on 3-inch Carpetmaster

SOCKETS

R-type — Round

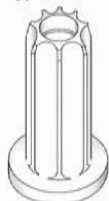

R-type — Square

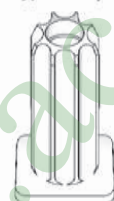

See page 20 (50 Series) for socket table.

Diameter	Tread Width	Load Capacity	Wheel Material	Bearing	Swivel Part Number	Rigid Part Number	Approx. Weight	Overall Height	Swivel Radius	
2	$15/16$	90	EXTRA SOFT NEOPRENE	BALL	C2-0-XEZN-RD	N/A	.7	2-3/4	2	
			ROUND DONUT / NEOPRENE	BALL	C2-0-XDN-RD	N/A				
			HI-CAP NEOPRENE	BALL	C2-0-XKN-RD	N/A				
			HARD RUBBER	BALL	C2-0-XH-RD	N/A				
3	$15/16$	100	EXTRA SOFT NEOPRENE	ACETAL	C3-0-PEZN-RD	N/A	1	4	3-1/16	
			ROUND DONUT / NEOPRENE	BALL	C3-0-XEZN-RD	N/A				
			ROUND DONUT / NEOPRENE	ACETAL	C3-0-PDN-RD	N/A				
			ROUND DONUT / NEOPRENE	BALL	C3-0-XDN-RD	N/A				
			STATIC DISAPATIVE POLYURETHANE	BALL	C3-0-XADI-SDX	N/A				
			STATIC DISAPATIVE POLYURETHANE	PLAIN	C3-0-BADI-SDX	N/A				
		135	HI-CAP NEOPRENE	ACETAL	C3-0-PKN-RD	N/A				
			HI-CAP NEOPRENE	BALL	C3-0-XKN-RD	N/A				
			165	HARD RUBBER	ACETAL	C3-0-PH-RD				N/A
				HARD RUBBER	BALL	C3-0-XH-RD				N/A