

SERIES

Twin Lock Casters

Load Capacity: 160 to 300 lbs.

Quality Features

- **LOCKS WHEEL & SWIVEL SIMULTANEOUSLY.**
Sturdy brake pedal is located above the wheel for easy access. Simply step down to apply, set again to release. Locks both wheel and swivel at the same time.
- **CHOICE OF STAINLESS STEEL OR ZINC PLATED.**
Applications in normal environments use stainless steel for maximum protection.
- **VARIETY OF MOUNTING ATTACHMENTS.**
Wide assortment of stem and mounting plate options to fit nearly all types of carts and equipment. Economical hollow king pin is also available with a 5/8" hole in swivel for inserting a bolt.
- **TWO-PIECE RIGID CASTER.**
Rigid caster utilizes a welded top plate and yoke design instead of a one-piece stamped yoke as used on competitive brands.
- **THREAD GUARDS.**
Keeps unwanted materials out of the wheel bearings thus increasing the life of the caster. Available only on zinc plated casters.

SWIVEL



RIGID



Options

- Grease Seals for Swivel Raceways
- High-Temperature Wheels
- Conductive or Static-Dissipative Wheels
- Gray, Non-Marking Wheels
- Powder Coated Finishes

DOUBLE BALL BEARING SWIVEL RACEWAY 90 SERIES

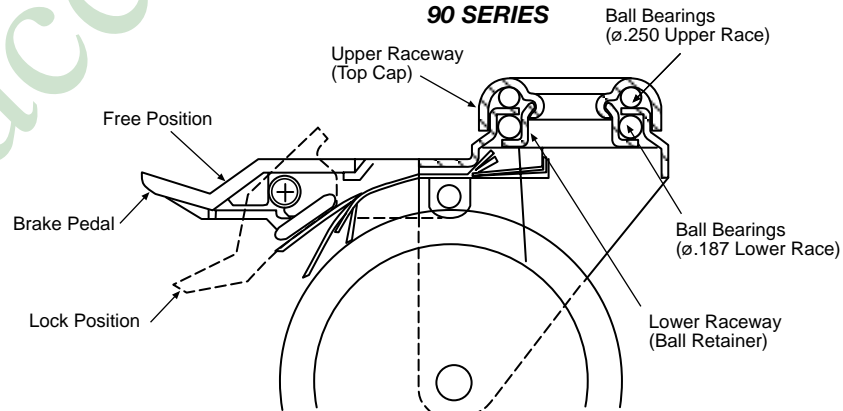

Twin Lock casters restrain movable equipment by locking both the wheel and the swivel in one easy step. Simply step down to lock, step again to release. No other caster combines this much braking action with ease of use. Available with a wide variety of stems and mounting plates, as well as the 5/8" hollow king pin for inserting a bolt.

Typical uses include:

- Medical Carts & Equipment
- Photography Lighting
- Wire Shelving Trucks
- Food Serving Carts
- Modular Frame Systems
- Electronics Equipment

Available in either corrosion resistant Zinc Plated Steel or in Stainless Steel for maximum corrosion protection.



Wheel Selection

NEOPRENE RUBBER

PAGE 108

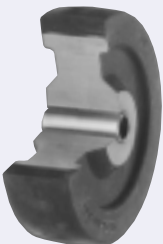

HI-CAP NEOPRENE

PAGE 110



NEOPRENE OR POLYURETHANE

STEEL DISC

PAGE 118



HARD RUBBER

PAGE 112



TOP PLATE

STANDARD

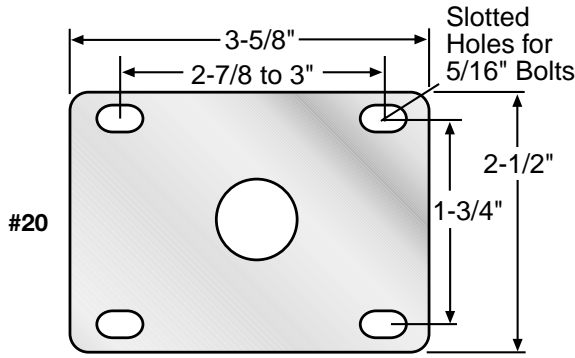

ALTERNATES

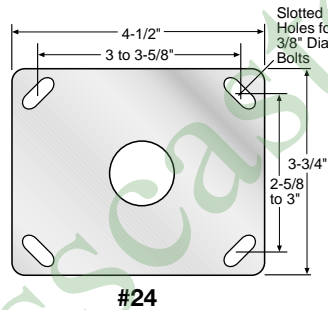
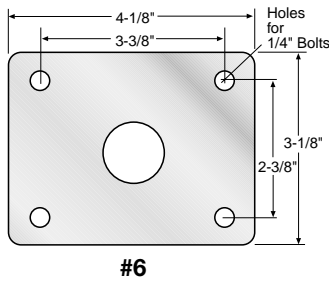
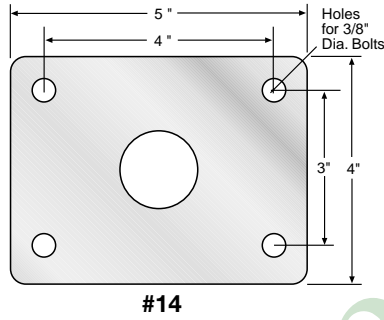
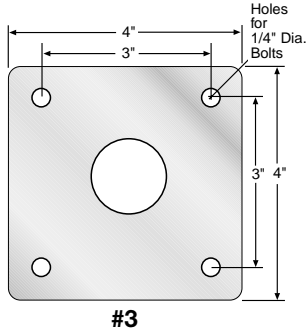

Twin Lock Casters



STEMS

"O" STEM TABLE

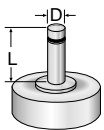

Dimension D	Dimension L	Stem Number
*1/2"	1-1/2"	O90-12-112
*5/8"	2"	O90-58-2
*3/4"	2"	O90-34-2
*7/8"	2"	O90-78-2
*1"	2-1/2"	O90-1-212

Other stem sizes and dimensions available.
*Special Order/Minimum Quantity

"L" STEM TABLE

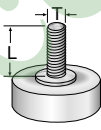

Dimension T	Dimension L	Stem Number
*1/2"-13	1-1/2"	L90-1213-112
*1/2"-13	2"	L90-1213-2
*5/8"-11	2"	L90-5811-2
5/8"-11	2-1/2"	L90-5811-212
*3/4"-10	1-1/2"	L90-3410-112
*3/4"-10	2"	L90-3410-2
*3/4"-10	2-1/2"	L90-3410-212

Other stem sizes and dimensions available.
*Special Order/Minimum Quantity

"E" STEM TABLE

Dimension D	
ROUND	SQUARE
3/4"	3/4"
7/8"	7/8"
1"	1"
1-1/16"	1-1/8"
1-1/8"	1-1/4"
1-1/4"	1-3/8"
1-3/8"	1-1/2"
1-7/16"	1-5/8"
1-1/2"	1-3/4"
1-9/16"	2"
1-5/8"	
1-3/4"	
1-7/8"	
1.9"	

"7/8" round" stem

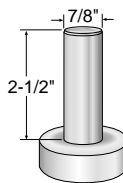

"7/8" square" stem

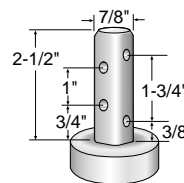

Subtract .187" from overall height for stem casters.

POLYOLEFIN HUB

POLYURETHANE

PAGE 126

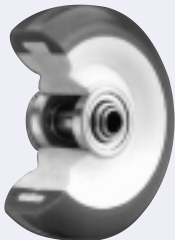

THERMO PLASTIC RUBBER

PAGE 124



PHENOLIC

PAGE 134



POLYOLEFIN

PAGE 136



90 Series

Diameter	Tread Width	Load Capacity	Wheel Material	Bearing	Twin Lock Part Number	Swivel Part Number	Rigid Part Number	Approx. Weight	Overall Height	Swivel Radius
3 1/2	1 1/4	200	NEOPRENE RUBBER	ACETAL	93 1/2-20-PDN-TL	93 1/2-20-PDN	93 1/2-20-PRDN	2-1/4	5	3-1/16
			BALL	93 1/2-20-XDN-TL	93 1/2-20-XDN	93 1/2-20-XRDN				
		250	HI-CAP NEOPRENE	ACETAL	93 1/2-20-PKN-TL	93 1/2-20-PKN	93 1/2-20-PRKN			
			BALL	93 1/2-20-XKN-TL	93 1/2-20-XKN	93 1/2-20-XRKN				
		300	HARD RUBBER	ACETAL	93 1/2-20-PH-TL	93 1/2-20-PH	93 1/2-20-PRH			
			BALL	93 1/2-20-XH-TL	93 1/2-20-XH	93 1/2-20-XRH				
	PHENOLIC	ROLLER	93 1/2-20-TPR-TL	93 1/2-20-TPR	93 1/2-20-TRPR					
	1 3/8	160	EXTRA SOFT THERMO-PLASTIC RUBBER	BALL	93 1/2-20-XPD-M-PO-55-TL	93 1/2-20-XPD-M-PO-55	93 1/2-20-XRPD-M-PO-55	2-1/8		
			DELTRIN	93 1/2-20-DPD-M-PO-55-TL	93 1/2-20-DPD-M-PO-55	93 1/2-20-DRPD-M-PO-55				
		240	THERMO-PLASTIC RUBBER	BALL	93 1/2-20-XPD-M-PO-TL	93 1/2-20-XPD-M-PO	93 1/2-20-XRPD-M-PO			
			DELTRIN	93 1/2-20-DPD-M-PO-TL	93 1/2-20-DPD-M-PO	93 1/2-20-DRPD-M-PO				
		250	POLYOLEFIN	BALL	93 1/2-20-XPO-TL	93 1/2-20-XPO	93 1/2-20-XRPO			
PLAIN				93 1/2-20-BPO-TL	93 1/2-20-BPO	93 1/2-20-BRPO				
300	POLYURETHANE / POLYOLEFIN HUB	BALL	93 1/2-20-XADI-M-PO-TL	93 1/2-20-XADI-M-PO	93 1/2-20-XRADI-M-PO					
		DELTRIN	93 1/2-20-DADI-M-PO-TL	93 1/2-20-DADI-M-PO	93 1/2-20-DRADI-M-PO					
4	1 1/4	175	EXTRA SOFT NEOPRENE	BALL	94-20-XEZN-RD-TL	94-20-XEZN-RD	94-20-XREZN-RD	2-1/2	5-5/8	3-5/16
			DELTRIN	94-20-DEZN-RD-TL	94-20-DEZN-RD	94-20-DREZN-RD				
		200	NEOPRENE RUBBER	ACETAL	94-20-PDN-TL	94-20-PDN	94-20-PRDN			
			BALL	94-20-XDN-TL	94-20-XDN	94-20-XRDN				
		250	HI-CAP NEOPRENE	ACETAL	94-20-PKN-TL	94-20-PKN	94-20-PRKN			
			BALL	94-20-XKN-TL	94-20-XKN	94-20-XRKN				
	300	HARD RUBBER	ACETAL	94-20-PH-TL	94-20-PH	94-20-PRH				
		BALL	94-20-XH-TL	94-20-XH	94-20-XRH					
	PHENOLIC	ROLLER	94-20-TPR-TL	94-20-TPR	94-20-TRPR					
	1 3/8	170	EXTRA SOFT THERMO-PLASTIC RUBBER	BALL	94-20-XPD-M-PO-55-TL	94-20-XPD-M-PO-55	94-20-XRPD-M-PO-55	2-3/5		
			DELTRIN	94-20-DPD-M-PO-55-TL	94-20-DPD-M-PO-55	94-20-DRPD-M-PO-55				
		250	THERMO-PLASTIC RUBBER	BALL	94-20-XPD-M-PO-TL	94-20-XPD-M-PO	94-20-XRPD-M-PO			
			DELTRIN	94-20-DPD-M-PO-TL	94-20-DPD-M-PO	94-20-DRPD-M-PO				
		300	POLYOLEFIN	BALL	94-20-XPO-TL	94-20-XPO	94-20-XRPO			
				PLAIN	94-20-BPO-TL	94-20-BPO	94-20-BRPO			
	300	POLYURETHANE / POLYOLEFIN HUB	BALL	94-20-XADI-M-PO-TL	94-20-XADI-M-PO	94-20-XRADI-M-PO				
			DELTRIN	94-20-DADI-M-PO-TL	94-20-DADI-M-PO	94-20-DRADI-M-PO				
	5	1 1/4	175	EXTRA SOFT NEOPRENE	BALL	95-20-XEZN-RD-TL	95-20-XEZN-RD	95-20-XREZN-RD		
DELTRIN				95-20-DEZN-RD-TL	95-20-DEZN-RD	95-20-DREZN-RD				
200			NEOPRENE RUBBER	ACETAL	95-20-PDN-TL	95-20-PDN	95-20-PRDN			
			BALL	95-20-XDN-TL	95-20-XDN	95-20-XRDN				
250			HI-CAP NEOPRENE	ACETAL	95-20-PKN-TL	95-20-PKN	95-20-PRKN			
			BALL	95-20-XKN-TL	95-20-XKN	95-20-XRKN				
300		HARD RUBBER	ACETAL	95-20-PH-TL	95-20-PH	95-20-PRH				
		BALL	95-20-XH-TL	95-20-XH	95-20-XRH					
PHENOLIC		ROLLER	95-20-TPR-TL	95-20-TPR	95-20-TRPR					
1 3/8		180	EXTRA SOFT THERMO-PLASTIC RUBBER	BALL	95-20-XPD-M-PO-55-TL	95-20-XPD-M-PO-55	95-20-XRPD-M-PO-55	3-3/5		
			DELTRIN	95-20-DPD-M-PO-55-TL	95-20-DPD-M-PO-55	95-20-DRPD-M-PO-55				
		275	THERMO-PLASTIC RUBBER	BALL	95-20-XPD-M-PO-TL	95-20-XPD-M-PO	95-20-XRPD-M-PO			
			DELTRIN	95-20-DPD-M-PO-TL	95-20-DPD-M-PO	95-20-DRPD-M-PO				
		300	POLYOLEFIN	BALL	95-20-XPO-TL	95-20-XPO	95-20-XRPO			
				PLAIN	95-20-BPO-TL	95-20-BPO	95-20-BRPO			
300		POLYURETHANE / POLYOLEFIN HUB	BALL	95-20-XADI-M-PO-TL	95-20-XADI-M-PO	95-20-XRADI-M-PO				
			DELTRIN	95-20-DADI-M-PO-TL	95-20-DADI-M-PO	95-20-DRADI-M-PO				

Members of:



NATIONAL SANITATION FOUNDATION



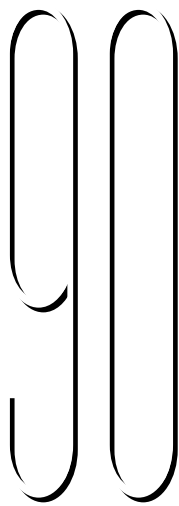

SERIES

Stainless Steel



Diameter	Tread Width	Load Capacity	Wheel Material	Bearing	Twin Lock Part Number	Swivel Part Number	Rigid Part Number	Approx. Weight	Overall Height	Swivel Radius						
		 LBS						 LBS								
3 1/2	1 1/4	200	NEOPRENE RUBBER	ACETAL	93 1/2-20-PDN-SS-TL	93 1/2-20-PDN-SS	93 1/2-20-PRDN-SS	2-1/4	5	3-1/16						
		250	HI-CAP NEOPRENE	ACETAL	93 1/2-20-PKN-SS-TL	93 1/2-20-PKN-SS	93 1/2-20-PRKN-SS									
		300	HARD RUBBER	ACETAL	93 1/2-20-PH-SS-TL	93 1/2-20-PH-SS	93 1/2-20-PRH-SS									
	1 3/8	160	EXTRA SOFT THERMO-PLASTIC RUBBER	DELTRIN	93 1/2-20-DPR-SS-TL	93 1/2-20-DPR-SS	93 1/2-20-DRPR-SS	2-1/8								
			240	THERMO-PLASTIC RUBBER	DELTRIN	93 1/2-20-DPD-M-PO-SS-TL	93 1/2-20-DPD-M-PO-SS				93 1/2-20-DRPD-M-PO-SS					
		250	POLYOLEFIN	PLAIN	93 1/2-20-BPO-SS-TL	93 1/2-20-BPO-SS	93 1/2-20-BRPO-SS	2-1/4								
			POLYURETHANE / POLYOLEFIN HUB	DELTRIN	93 1/2-20-DADI-M-PO-SS-TL	93 1/2-20-DADI-M-PO-SS	93 1/2-20-DRADI-M-PO-SS									
			4	1 1/4	175	EXTRA SOFT NEOPRENE	DELTRIN				94-20-DEZN-RD-SS-TL	94-20-DEZN-RD-SS	94-20-DREZN-RD-SS	2-1/2	5-5/8	3-5/16
					200	NEOPRENE RUBBER	ACETAL				94-20-PDN-SS-TL	94-20-PDN-SS	94-20-PRDN-SS			
250	HI-CAP NEOPRENE	ACETAL	94-20-PKN-SS-TL		94-20-PKN-SS	94-20-PRKN-SS										
1 3/8	300	HARD RUBBER	ACETAL	94-20-PH-SS-TL	94-20-PH-SS	94-20-PRH-SS	2-3/5									
		PHENOLIC	DELTRIN	94-20-DPR-SS-TL	94-20-DPR-SS	94-20-DRPR-SS										
	170	EXTRA SOFT THERMO-PLASTIC RUBBER	DELTRIN	94-20-DPD-M-PO-SS-TL	94-20-DPD-M-PO-SS	94-20-DRPD-M-PO-SS	2-3/5									
		250	THERMO-PLASTIC RUBBER	DELTRIN	94-20-DPD-M-PO-SS-TL	94-20-DPD-M-PO-SS		94-20-DRPD-M-PO-SS								
		300	POLYOLEFIN	PLAIN	94-20-BPO-SS-TL	94-20-BPO-SS		94-20-BRPO-SS								
			POLYURETHANE / POLYOLEFIN HUB	DELTRIN	94-20-DADI-M-PO-SS-TL	94-20-DADI-M-PO-SS		94-20-DRADI-M-PO-SS								
5	1 1/4	175	EXTRA SOFT NEOPRENE	DELTRIN	95-20-DEZN-RD-SS-TL	95-20-DEZN-RD-SS	95-20-DREZN-RD-SS	3-1/2	6-5/8	3-13/16						
		200	NEOPRENE RUBBER	ACETAL	95-20-PDN-SS-TL	95-20-PDN-SS	95-20-PRDN-SS									
		250	HI-CAP NEOPRENE	ACETAL	95-20-PKN-SS-TL	95-20-PKN-SS	95-20-PRKN-SS									
		300	HARD RUBBER	ACETAL	95-20-PH-SS-TL	95-20-PH-SS	95-20-PRH-SS									
		PHENOLIC	DELTRIN	95-20-DPR-SS-TL	95-20-DPR-SS	95-20-DRPR-SS										
	1 3/8	180	EXTRA SOFT THERMO-PLASTIC RUBBER	DELTRIN	95-24-DPD-M-PO-SS-TL	95-24-DPD-M-PO-SS	95-24-DRPD-M-PO-SS	3-3/5								
		275	THERMO-PLASTIC RUBBER	DELTRIN	95-24-DPD-M-PO-SS-TL	95-24-DPD-M-PO-SS	95-24-DRPD-M-PO-SS									
		300	POLYOLEFIN	PLAIN	95-20-BPO-SS-TL	95-20-BPO-SS	95-20-BRPO-SS									
			POLYURETHANE / POLYOLEFIN HUB	DELTRIN	95-20-DADI-M-PO-SS-TL	95-20-DADI-M-PO-SS	95-20-DRADI-M-PO-SS									

Designed to provide the ultimate

CORROSION PROTECTION

These casters are ideally suited for acetic, nitric and citric acid environments in addition to being well suited for organic and inorganic chemicals, dye stuffs, crude and refined oil environments. Widely accepted in the following industries:

- DAIRY
- BEVERAGE
- FOOD PROCESSING
- PHARMACEUTICALS
- HOSPITALS & MEDICAL
- ANIMAL CAGES